

Gas Discharge Tube

3R075~3R600T/S/L/CB_D-8 Series

GDTs (Gas Discharge Tubes) are placed in front of, and in parallel with, sensitive telecom equipment such as power lines, communication lines, signal lines and data transmission lines to help protect them from damage caused by transient surge voltages that may result from lightning strikes and equipment switching operations. These devices do not influence the signal in normal operation. However, in the event of an overvoltage surge, such as a lightning strike, the GDT switches to a low impedance state and diverts the energy away from the sensitive equipment.

GDTs offer a high level of surge protection, a broad voltage range, low capacitance, and many form factors including new surface mount devices, which makes them suitable for applications such as MDF (Main Distribution Frame) modules, high data-rate telecom applications (e.g. ADSL, VDSL), and surge protection on power lines. Their low capacitance also results in less signal distortion. When used in a coordinated circuit protection solution with PTC devices, TSS thyristor surge protection devices, and MOV (Metal Oxide Varistor) devices, they can help equipment manufacturers meet

ROHS



Features

- RoHS compliant and Lead-free
- GHz working frequency
- Excellent stability on multiple pulse duty cycle
- Excellent response to fast rising transients.
- Ultra Low Insertion Loss
- Compact, small form factor suitable for efficient assembly
- Helps provide overvoltage fault protection against high energy surges
- Suitable for high-frequency applications
- 8.0*10.0mm devices
- Broad voltage range from 75V-600V
- Various form factors: surface mount, axial leads, no leads
- Low capacitance and insertion loss
- RoHS compliant
- Devices tested per ITU K.12 recommendations
- Non-radioactive materials

Applications

- Communication equipment
- CATV equipment
- Test equipment
- Data lines
- Power supplies
- Telecom SLIC protection
- Broadband equipment
- ADSL equipment including ADSL2+
- XDSL equipment
- Satellite and CATV equipment
- General telecom equipment

Electrical Characteristics

Type number	DC Spark-over voltage	Maximum Impulse spark-over voltage	Impulse life 10/1000us, 100A	Minimum Insulation resistance		Maximum Capacitance	Maximum surge Discharge Current @8/20us,10times	Alternating Discharge Current
	V @100v/s	V @1kv/us	Times	Test Voltage	GΩ	pF @1MHz	KA	A @50Hz 1S
3R075(T,S,L,C)B-8	75±20%	750	300 times	DC 25V >1	2.0 pF	10KA	10	
3R090(T,S,L,C)B-8	90±20%	750		DC 50V >1				
3R150(T,S,L,C)B-8	150±20%	800		DC 100V >1				
3R230(T,S,L,C)B-8	230±20%	800						
3R300(T,S,L,C)B-8	300±20%	800						
3R350(T,S,L,C)B-8	350±20%	800						
3R400(T,S,L,C)B-8	400±20%	850		DC 250V >1				
3R420(T,S,L,C)B-8	420±20%	850						
3R470(T,S,L,C)B-8	470±20%	950						
3R600(T,S,L,C)B-8	600±20%	1300						
3R075(T,S,L,C)D-8	75±20%	750		DC 25V >1		20KA	20	
3R090(T,S,L,C)D-8	90±20%	750		DC 50V >1				
3R150(T,S,L,C)D-8	150±20%	800		DC 100V >1				
3R230(T,S,L,C)D-8	230±20%	800						
3R300(T,S,L,C)D-8	300±20%	800						
3R350(T,S,L,C)D-8	350±20%	800						
3R400(T,S,L,C)D-8	400±20%	850		DC 250V >1				
3R420(T,S,L,C)D-8	420±20%	950						
3R470(T,S,L,C)D-8	470±20%	950						
3R600(T,S,L,C)D-8	600±20%	1300						

Notes:

- Insulation resistance measure at:
DC 50V for the 3R075,3R090,and 3R150
DC 200V for other.
- Terms in accordance with ITU-T K.12 and GB/T 9043-2008
- At delivery AQL 0.65 level 2 DIN ISO 2859

Device Dimensions

NOTE: Failsafe option dimensions shown in

Type S - Surface Mount Core

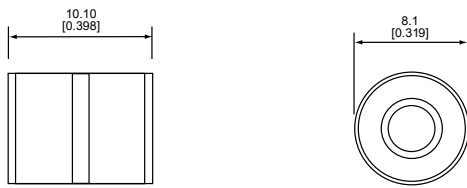

Type T - Shaped Radial Leads

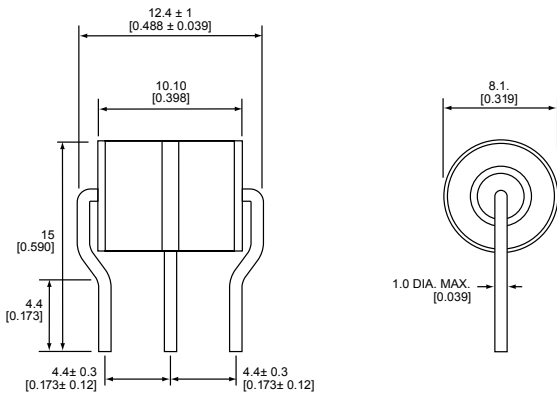

Type L - Straight Radial Leads

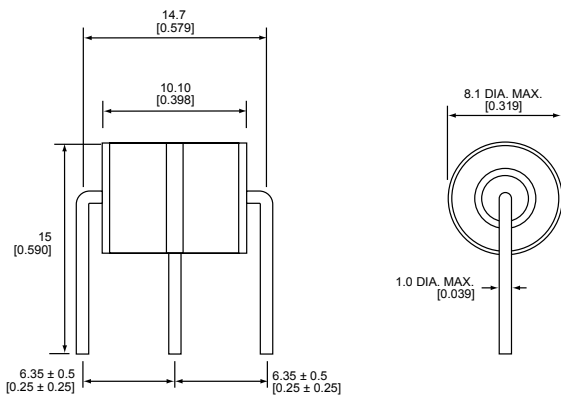

Type C - Straight "C" Leads

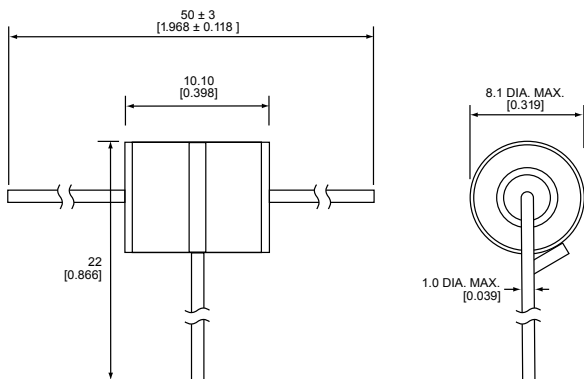

Packaging

Device Type	Description	Quantity
Type S	100pcs/tray x 5 trays per carton	500
Type T	100pcs/tray x 5 trays per carton	500
Type L	100pcs/tray x 5 trays per carton	500
Type C	50pcs/tray x 5 trays per carton	250

Product Characteristics

Materials	Dull Tin Plate 17.5 ± 12.5 Microns with Ceramic Insulator
Product Marking	Littelfuse 'LF' marking, Voltage and date code.
Glow to arc transition current	~ 1Amp
Glow Voltage	~ 60-200 Volts

Storage and Operational Temperature	-40 to +90°C
Transverse Voltage (Delay Time) Tested to ITU-T Rec. K.12	< 0.2µSec
Arc Voltage	~ 10 to 35 Volts
Holdover Voltage Tested to ITU-T Rec. K.12 & REA PE 80	< 150mS

Soldering Parameters - Reflow Soldering (Surface Mount Devices)

Reflow Condition	Pb – Free assembly	
Pre Heat	- Temperature Min ($T_{s(min)}$)	150°C
	- Temperature Max ($T_{s(max)}$)	200°C
	- Time (Min to Max) (t_s)	60 – 180 secs
Average ramp up rate (Liquidus Temp (T_L) to peak)	3°C/second max	
$T_{s(max)}$ to T_L - Ramp-up Rate	5°C/second max	
Reflow	- Temperature (T_L) (Liquidus)	217°C
	- Temperature (t_L)	60 – 150 seconds
Peak Temperature (T_p)	260 ^{+0/-5} °C	
Time within 5°C of actual peak Temperature (t_p)	10 – 30 seconds	
Ramp-down Rate	6°C/second max	
Time 25°C to peak Temperature (T_p)	8 minutes Max.	
Do not exceed	260°C	

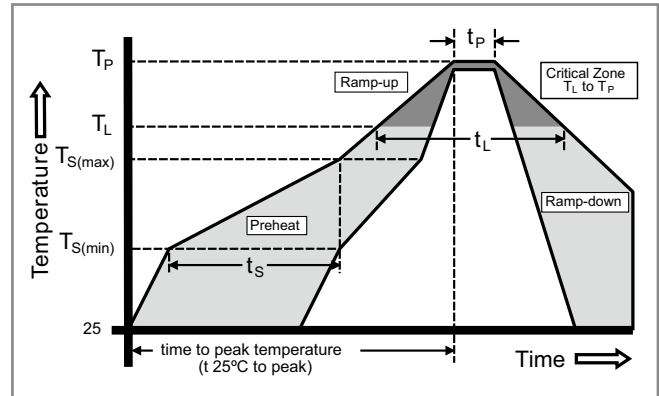

Soldering Parameters - Hand Soldering

Solder Iron Temperature: 350° C +/- 5°C
Heating Time: 5 seconds max.

Soldering Parameters - Wave Soldering (Thru-Hole Devices)

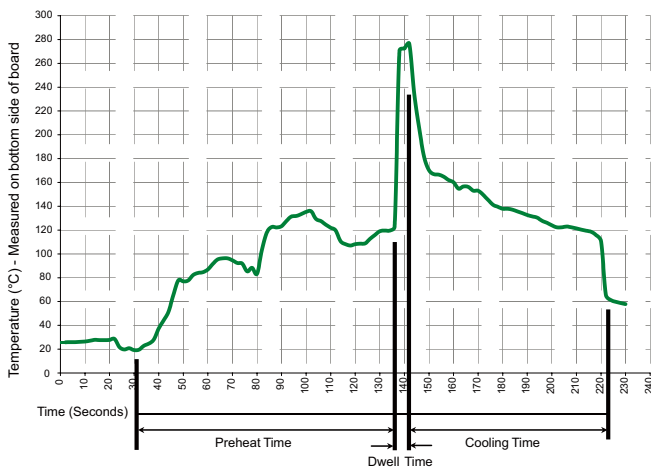

Recommended Process Parameters:

Wave Parameter	Lead-Free Recommendation
Preheat: (Depends on Flux Activation Temperature)	(Typical Industry Recommendation)
Temperature Minimum:	100° C
Temperature Maximum:	150° C
Preheat Time:	60-180 seconds
Solder Pot Temperature:	280° C Maximum
Solder Dwell Time:	2-5 seconds

Note: Surge Arrestors with a Failsafe mechanism should be individually examined after soldering

Part Number Code

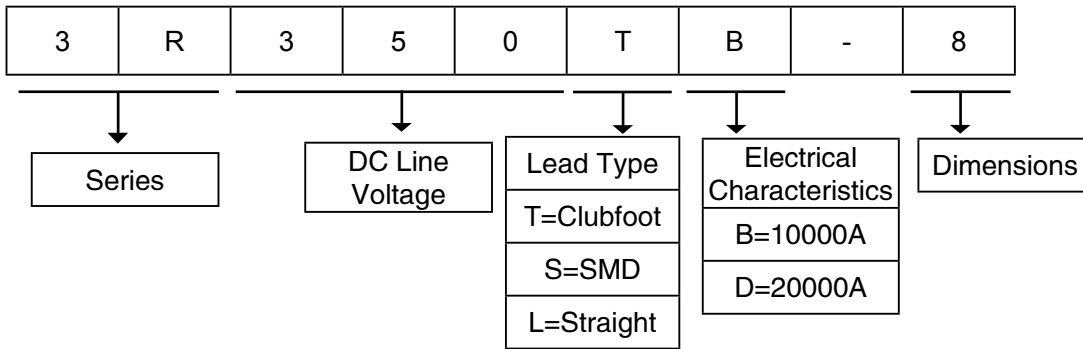

Leiditech Electronics are trademarks.

Information furnished is believed to be accurate and reliable. However, users should independently evaluate the suitability of and test each product selected for their own applications. Leiditech Electronics reserves the right to change or update, without notice, any information contained in this publication; to change, without notice, the design, construction, processing, or specification of any product; and to discontinue or limit production or distribution of any product. This publication supersedes and replaces all information previously supplied. Without expressed or written consent by an officer of Leiditech Electronics, Leiditech Electronics does not authorize the use of any of its products as components in nuclear facility applications, aerospace, or in critical life support devices or systems. Leiditech Electronics expressly disclaims all implied warranties regarding the information contained herein, including, but not limited to, any implied warranties of merchantability or fitness for a particular purpose. Leiditech Electronics' only obligations are those in the Leiditech Electronics Standard Terms and Conditions of Sale and in no case will Leiditech Electronics be liable for any incidental, indirect, or consequential damages.

SHANGHAI LEIDITECH ELECTRONICS CO.,LTD

Tel: +86- 021 50828806

Fax: +86- 021 50477059-8008

Email: sale1@leiditech.com

Website: <http://www.leiditech.com>