

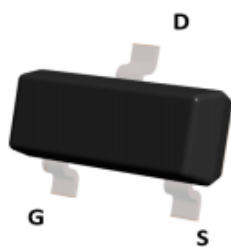

P-Channel Enhancement Mode Field Effect Transistor

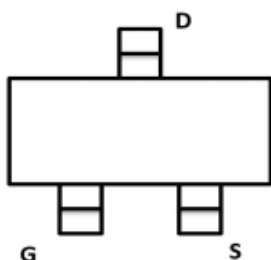

Top View

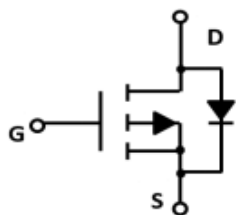

SOT-23-3

**Product Summary**

- V_{DS} -30V
- I_D -4.1A
- $R_{DS(ON)}$ (at $V_{GS}=-10V$) <55 mohm
- $R_{DS(ON)}$ (at $V_{GS}=-4.5V$) <68 mohm

General Description

- Trench Power LV MOSFET technology
- High density cell design for Low $R_{DS(ON)}$
- High Speed switching

Applications

- Battery protection
- Load switch
- Power management

■ Absolute Maximum Ratings ($T_A=25^\circ\text{C}$ unless otherwise noted)

Parameter	Symbol	Maximum	Unit
Drain-source Voltage	V_{DS}	-30	V
Gate-source Voltage	V_{GS}	± 20	V
Drain Current	I_D	$T_A=25^\circ\text{C}$ @ Steady State	-4.1
		$T_A=70^\circ\text{C}$ @ Steady State	-3.2
Pulsed Drain Current ^A	I_{DM}	-15	A
Total Power Dissipation @ $T_A=25^\circ\text{C}$	P_D	1.5	W
Thermal Resistance Junction-to-Ambient @ Steady State ^B	$R_{\theta JA}$	82	$^\circ\text{C}/\text{W}$
Junction and Storage Temperature Range	T_J, T_{STG}	-55~+150	$^\circ\text{C}$

■ Ordering Information (Example)

PREFERRED P/N	PACKING CODE	Marking	MINIMUM PACKAGE(pcs)	INNER BOX QUANTITY(pcs)	OUTER CARTON QUANTITY(pcs)	DELIVERY MODE
LM3407AL	F2	3407.	3000	30000	120000	7" reel

■ Electrical Characteristics (T_J=25°C unless otherwise noted)

Parameter	Symbol	Conditions	Min	Typ	Max	Units
Static Parameter						
Drain-Source Breakdown Voltage	BV _{DSS}	V _{GS} = 0V, I _D =-250μA	-30			V
Zero Gate Voltage Drain Current	I _{DSS}	V _{DS} =-30V, V _{GS} =0V, T _C =25°C			-1	μA
Gate-Body Leakage Current	I _{GSS}	V _{GS} = ±20V, V _{DS} =0V			±100	nA
Gate Threshold Voltage	V _{GS(th)}	V _{DS} = V _{GS} , I _D =-250μA	-1.0	-1.5	-2.4	V
Static Drain-Source On-Resistance	R _{DS(ON)}	V _{GS} = -10V, I _D =-4.1A		40	55	mΩ
		V _{GS} = -4.5V, I _D =-3.5A		53	68	
Diode Forward Voltage	V _{SD}	I _S =-4.1A, V _{GS} =0V		-0.8	-1.2	V
Maximum Body-Diode Continuous Current	I _S				-4.1	A
Dynamic Parameters						
Input Capacitance	C _{iss}	V _{DS} =-15V, V _{GS} =0V, f=1MHZ		580		pF
Output Capacitance	C _{oss}			98		
Reverse Transfer Capacitance	C _{rss}			74		
Switching Parameters						
Total Gate Charge	Q _g	V _{GS} =-10V, V _{DS} =-15V, I _D =-4.1A		6.8		nC
Gate Source Charge	Q _{gs}			1.0		
Gate Drain Charge	Q _{gd}			1.4		
Turn-on Delay Time	t _{D(on)}	V _{GS} =-10V, V _{DD} =-15V, R _L =15Ω, I _D =-1A, R _{GEN} =2.5Ω		14		ns
Turn-on Rise Time	t _r			61		
Turn-off Delay Time	t _{D(off)}			19		
Turn-off Fall Time	t _f			10		

A. Pulse Test: Pulse Width ≤ 300us, Duty cycle ≤ 2%.

B. Device mounted on FR-4 PCB, 1 inch x 0.85 inch x 0.062 inch.

■ Typical Performance Characteristics

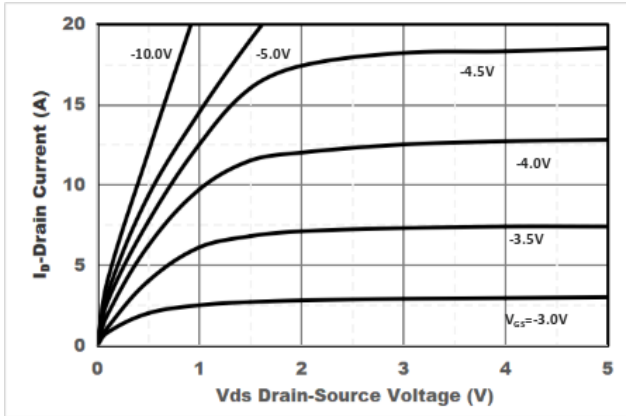

Figure1. Output Characteristics

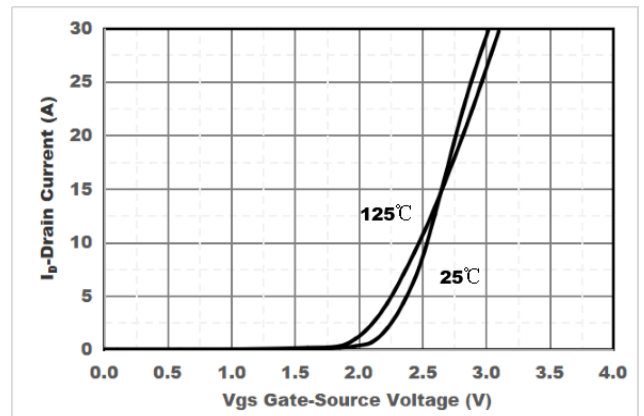

Figure2. Transfer Characteristics

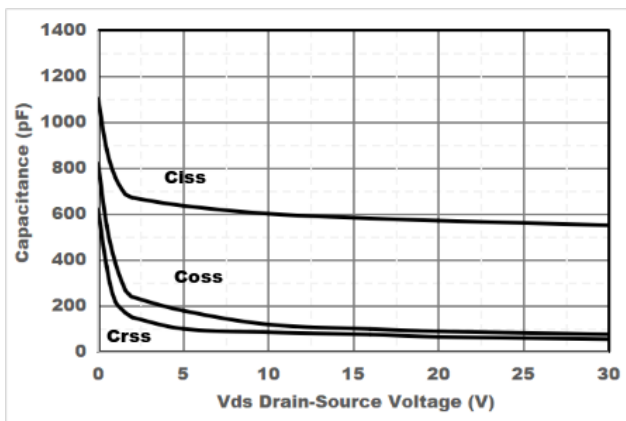

Figure3. Capacitance Characteristics

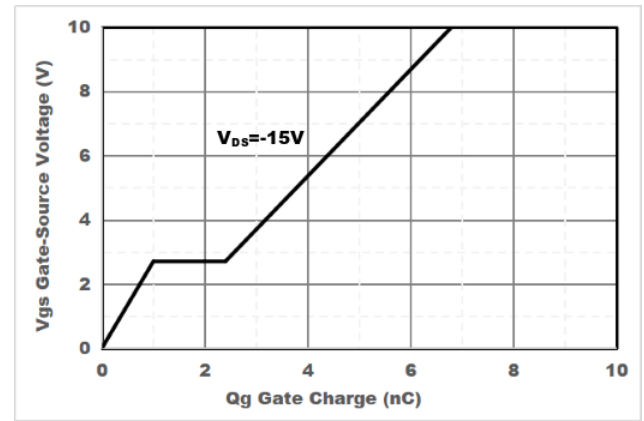

Figure4. Gate Charge

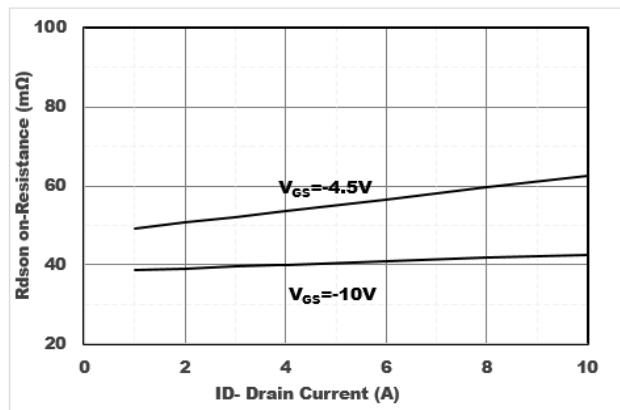

Figure5. Drain-Source on Resistance

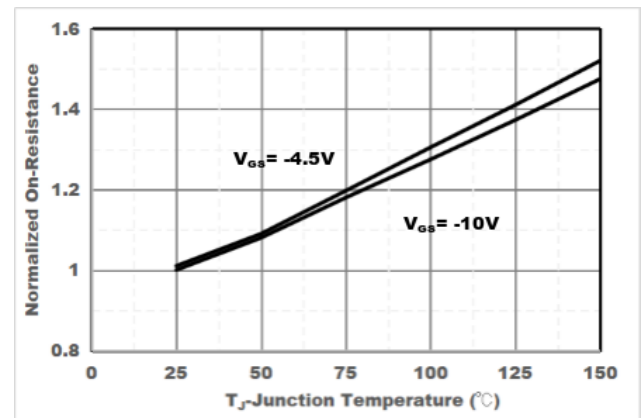

Figure6. Drain-Source on Resistance

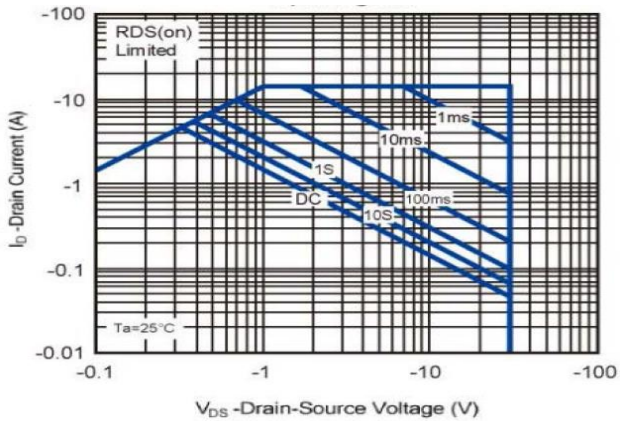

Figure7. Safe Operation Area

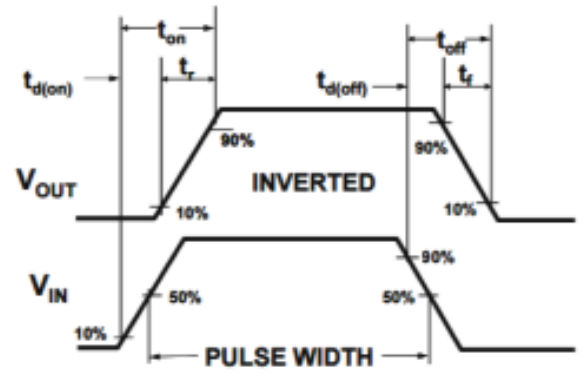
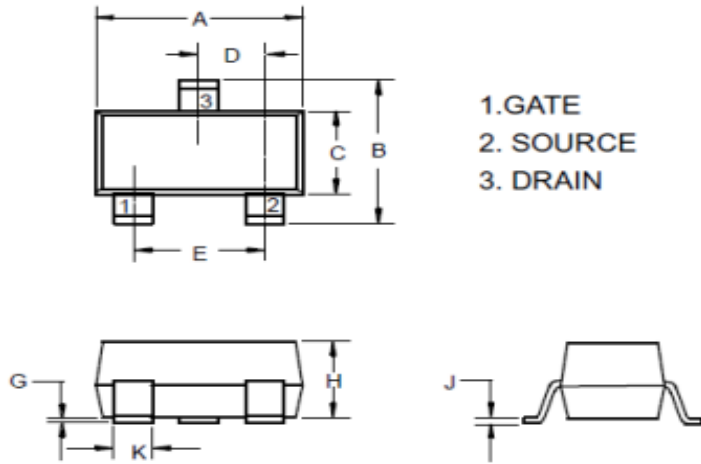

Figure8. Switching wave

■ SOT-23-3 Package information

SOT-23-3



DIM	DIMENSIONS				NOTE
	INCHES		MM		
	MIN	MAX	MIN	MAX	
A	.113	.117	2.87	2.97	
B	.108	.112	2.75	2.85	
C	.061	.065	1.55	1.65	
D	.036	.038	.914	.965	
E	.073	.077	1.85	1.95	
G	.0016	.0039	.04	.100	
H	.044	.049	1.12	1.25	
J	.006	.007	.14	.17	
K	.013	.015	.34	.37	

■ SOT-23-3 Suggested Pad Layout

