

### 1. FEATURES

- Power MOSFET: 1.8-V Rated
- Gate-Source ESD Protected
- High-Side Switching
- Low On-Resistance: 0.7Ω
- Low Threshold: 0.8 V (typ)
- Fast Switching Speed: 10 ns
- We declare that the material of product compliance with RoHS requirements and Halogen Free.
- S- prefix for automotive and other applications requiring unique site and control change requirements; AEC-Q101 qualified and PPAP capable.

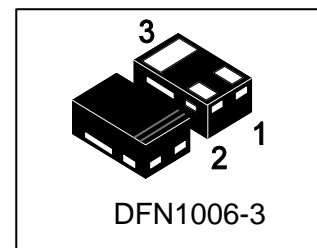
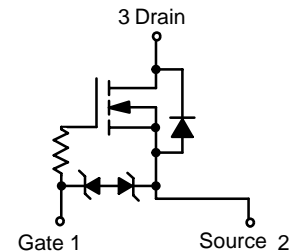

### 2. BENEFITS

- Ease in Driving Switches
- Low Offset (Error) Voltage
- Low-Voltage Operation
- High-Speed Circuits
- Low Battery Voltage Operation

### 3. APPLICATIONS

- Drivers: Relays, Solenoids, Lamps, Hammers, Displays, Memories.
- Battery Operated Systems
- Power Supply Converter Circuits
- Load/Power Switching Cell Phones, Pagers

### 4. DEVICE MARKING AND ORDERING INFORMATION

| Device   | Marking | Shipping        |
|----------|---------|-----------------|
| LM1012N3 | N5      | 10000/Tape&Reel |

### 5. MAXIMUM RATINGS(Ta = 25°C)

| Parameter  | Symbol    | 5 secs    | Steady State | Unit |
|--|-----------|-----------|--------------|------|
| Drain-Source Voltage                                 | VDS       | 20        |              | V    |
| Gate-Source Voltage                                  | VGS       | ±6        |              | V    |
| Continuous Drain Current (TJ = 150°C)<br>(Note 2)    | ID        | TA = 25°C | 500          | mA   |
|  |           | TA = 85°C | 350          |      |
| Pulsed Drain Current(Note 1)                         | IDM       | 1000      |              |      |
| Continuous Source Current (diode conduction)(Note 2) | IS        | 275       | 250          |      |
| Maximum Power Dissipation(Note 2)                    | PD        |           | 250          | mW   |
| Thermal Resistance, Junction to Ambient              | RθJA      |           | 500          | °C/W |
| Operating Junction and Storage Temperature Range     | TJ , Tstg | -55 ~+150 |              | °C   |

- 1.Pulse width limited by maximum junction temperature.
- 2.Surface Mounted on FR4 Board.

## 6. ELECTRICAL CHARACTERISTICS (Ta= 25°C)

### Static

| Characteristic   | Symbol  | Min. | Typ.                | Max.              | Unit     |
|--|---------|------|---------------------|-------------------|----------|
| Gate Threshold Voltage<br>(VDS = VGS , ID = 250μA )  | VGS(th) | 0.3  | -                   | 1.0               | V        |
| Gate-Body Leakage<br>(VDS = 0 V, VGS = ±4.5 V)   | IGSS    | -    | ±0.5                | ±1                | μA       |
| Zero Gate Voltage Drain Current<br>(VDS = 20 V, VGS = 0 V )<br>(VDS = 20 V, VGS = 0 V, TJ = 85°C)                                  | IDSS    | -    | 0.3                 | 100               | nA<br>μA |
| On-State Drain Current(Note 1)<br>(VDS = 5 V, VGS = 4.5 V)   | ID(on)  | 700  | -                   | -                 | mA       |
| Drain-Source On-State Resistance(Note 1)<br>(VGS = 4.5 V, ID = 600 mA)<br>(VGS = 2.5 V, ID = 500 mA)<br>(VGS = 1.8 V, ID = 350 mA) | RDS(on) |      | 0.41<br>0.53<br>0.7 | 0.6<br>0.7<br>0.9 | Ω        |
| Forward Transconductance(Note 1)<br>(VDS = 10 V, ID = 400 mA)  | gfs     |      | 1                   |                   | S        |
| Diode Forward Voltage(Note 1)<br>(IS = 150 mA, VGS = 0 V)  | VSD     |      | 0.8                 | 1.2               | V        |

### Dynamic(Note 2)

|                     |  |         |  |     |  |    |
|---------------------|--|---------|--|-----|--|----|
| Total Gate Charge   | (VDS = 10 V,<br>VGS = 4.5 V, ID<br>= 250 mA)                       | Qg      |  | 750 |  | pC |
| Gate-Source Charge  |  | Qgs     |  | 75  |  |    |
| Gate-Drain Charge   |  | Qgd     |  | 225 |  |    |
| Turn-On Delay Time  | (VDD = 10 V, RL<br>= 47Ω, ID=200<br>mA, VGEN = 4.5<br>V, RG = 10Ω) | td(on)  |  | 5   |  | ns |
| Rise Time           |  | tr      |  | 5   |  |    |
| Turn-Off Delay Time |  | td(off) |  | 25  |  |    |
| Fall Time           |  | tf      |  | 11  |  |    |

3.Pulse test; pulse width  $\leq 300 \mu\text{s}$ , duty cycle  $\leq 2\%$ .

4.Guaranteed by design, not subject to production testing.

## 7. ELECTRICAL CHARACTERISTICS CURVES

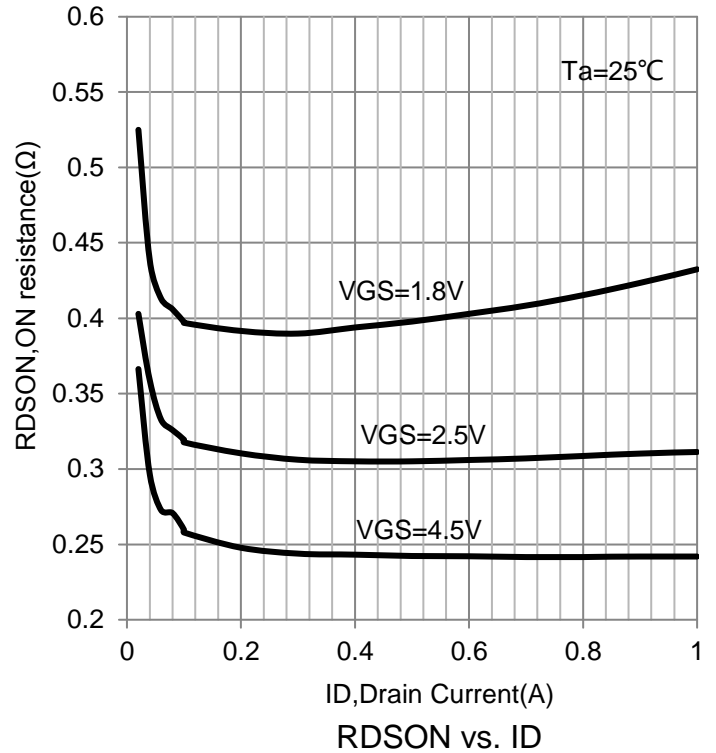
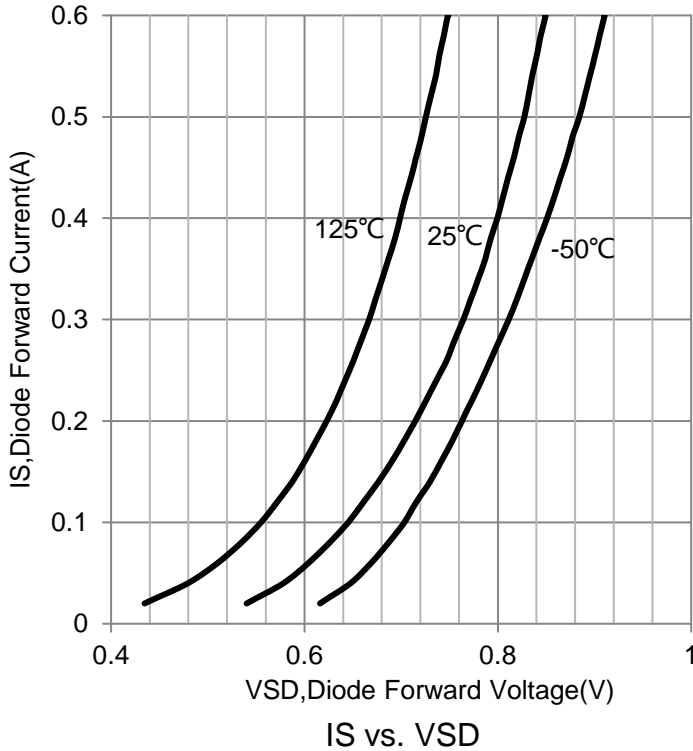
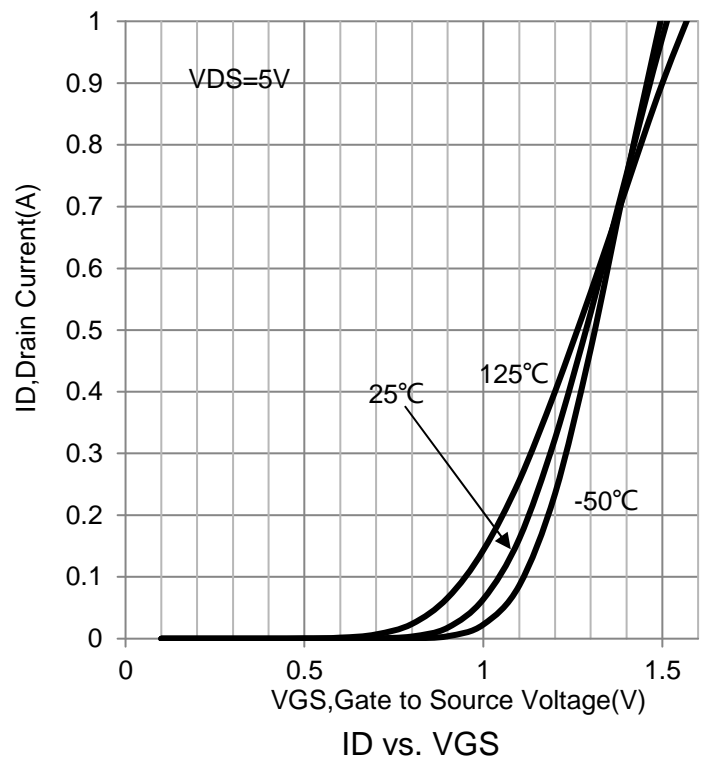
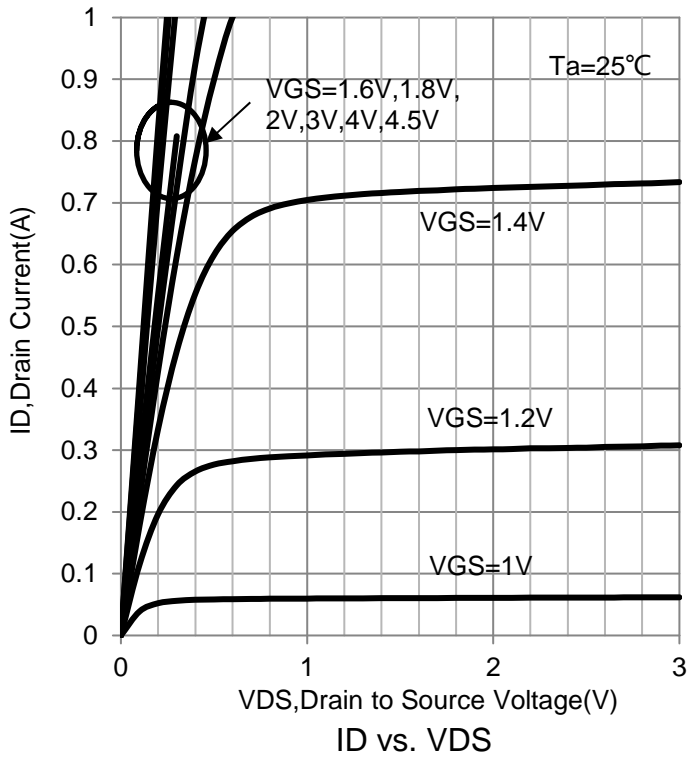

## 7. ELECTRICAL CHARACTERISTICS CURVES (Con.)

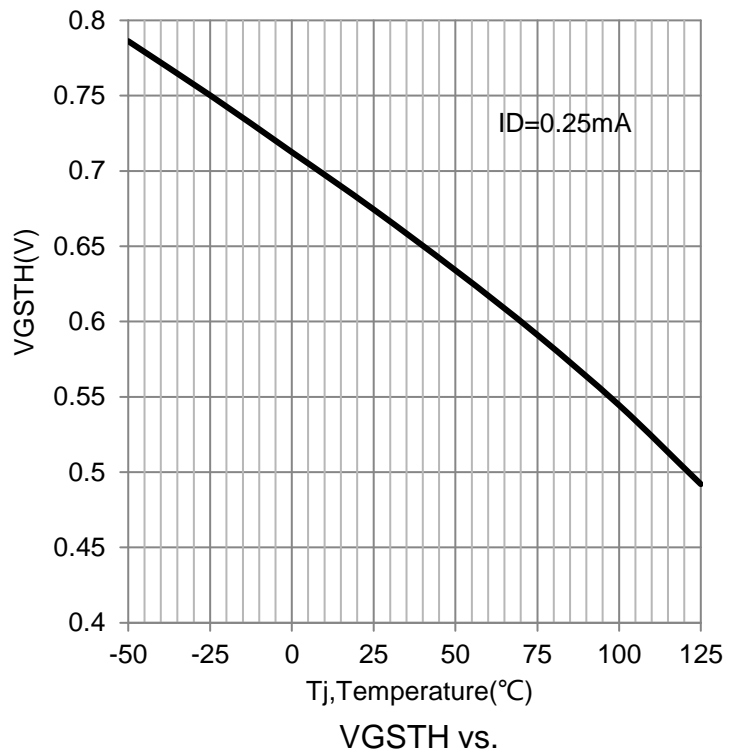
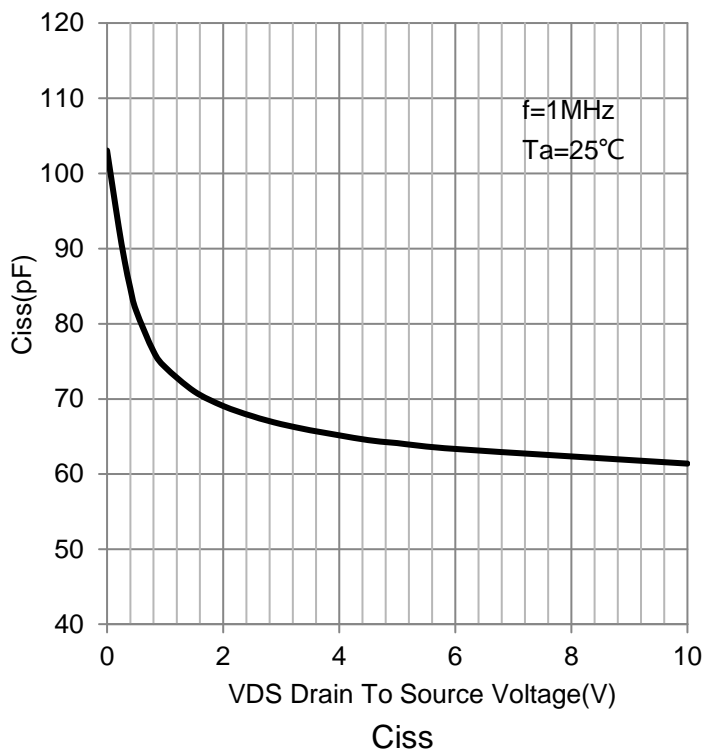
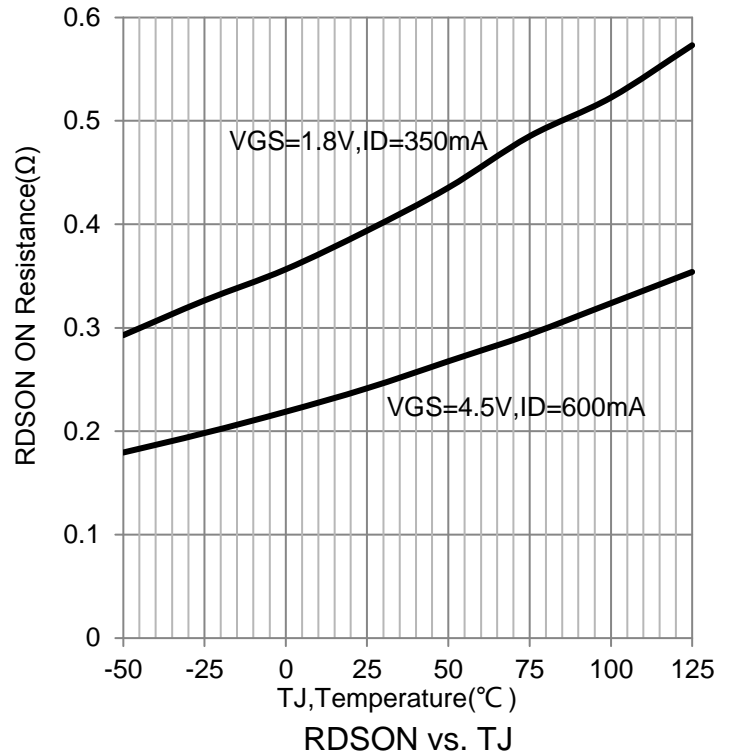
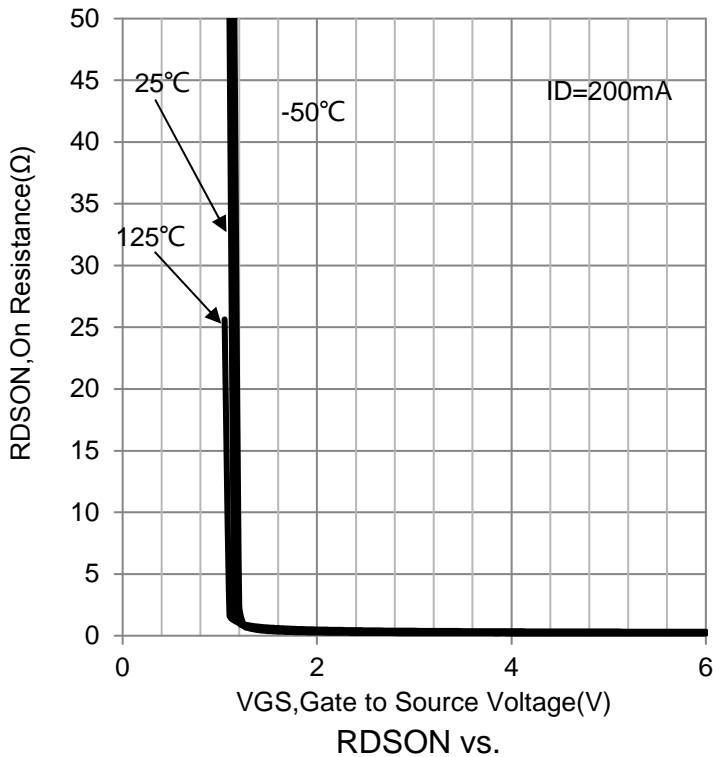

## 8. OUTLINE AND DIMENSIONS

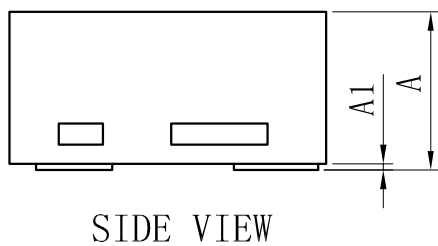
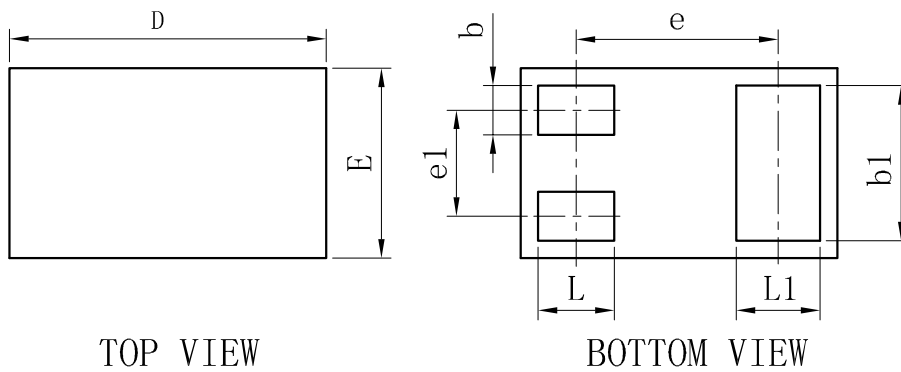

| SOT883               |      |      |      |
|----------------------|------|------|------|
| DIM                  | MIN  | TYP  | MAX  |
| D                    | 0.95 | 1.00 | 1.05 |
| E                    | 0.55 | 0.60 | 0.65 |
| e                    | -    | 0.64 | -    |
| e1                   | -    | 0.34 | -    |
| L                    | 0.19 | 0.24 | 0.29 |
| L1                   | 0.22 | 0.27 | 0.32 |
| b                    | 0.10 | 0.15 | 0.20 |
| b1                   | 0.44 | 0.49 | 0.54 |
| A                    | 0.43 | 0.48 | 0.53 |
| A1                   | 0    | -    | 0.05 |
| All Dimensions in mm |      |      |      |

## 9. SOLDERING FOOTPRINT

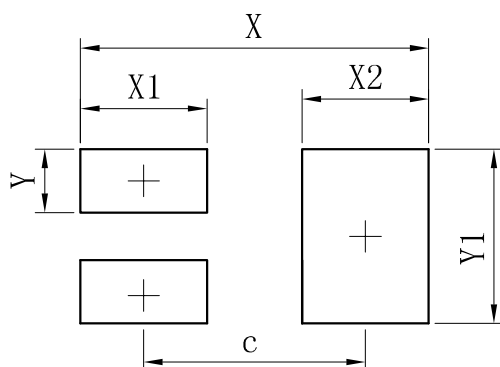

| Dimensions | (mm) |
|------------|------|
| c          | 0.70 |
| X          | 1.10 |
| X1         | 0.40 |
| X2         | 0.40 |
| Y          | 0.20 |
| Y1         | 0.55 |